



Alubond

U.S.A

Aluminum Composite Panels

American Building Technologies INC



A

b

o

u

n

d



ALUBOND® U.S.A - A DESIGNER SOLUTION FOR MODERN BUILDINGS

Alubond® U.S.A is the brand name for the new technology Aluminum Composite Building Panel from American Building Technologies, Denver U.S.A. The panel is a composite consisting of two layers of aluminum-skin sandwiching a thermoplastic core in a continuous co-extrusion process. This new generation technology of mechanical and chemical bonding gives Alubond Panels an exceptional bond integrity.

The outer aluminum skin for exterior grade Alubond® U.S.A Panels is coated with PVDF Kynar 500 fluorocarbon coatings. The lower aluminum skin is chromate treated and polyester coated.

Product Composition



- Kynar 500 Coating
- Epoxy Resin Primer
- Chromate Treatment
- Aluminum Skin
- P.E or Fire Rated Mineral
Core 3 mm
- Aluminum Skin
- Epoxy Resin Primer
- Service Coat

ALUBOND PRODUCT ADVANTAGES

- Lightweight, extreme rigidity and flatness resulting in an economical option for high quality building facades and interior claddings.
- Weather resistance combined with high acoustics, Thermal and Fire rated values.
- Choice of Solid, Metallic, Granite, Veneer and Chameleon colors makes ALUBOND an Architect's dream for a choice of interior and exterior facade's treatment.
- Easy machinability gives the flexibility of shapes making it a versatile panel to achieve complex designer solutions.

Comparison Chart between ALUBOND, Solid Aluminum and steel

Alubond Aluminum Composite Panels have distinct advantages over other popular Cladding materials like Solid Aluminum and Steel with superior Strength to weight ratio as well as flatness, thermal and acoustic properties to name a few.

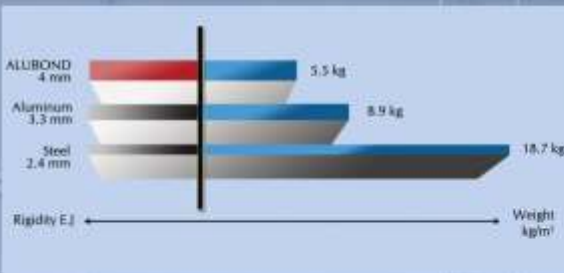

Comparison of thickness and weight on equivalent rigidity

ITEM	ALUBOND	SOLID Aluminum	STEEL
Weight	4 mm: 5.48 kg/m ²	3 mm: 8.0 kg/m ²	1.5 mm: 11.47kg/m ²
Flatness	Very Flat	Uneven	Uneven
Heat Insulation	Best	Poor	Poor
Sound Insulation	25db	15db	5db
Echo Response	Low	Medium	High
Paint Consistency	Best	Inconsistent	Inconsistent
Paint Microns	Even	Uneven	Uneven
Weather Proof	Good	Good	Good
Fire Proof	Good	Good	Good
Fabrication	Easy	Difficult	Very Tough
Delivery	Quick	Slow	Slow
Total Cost	Economical	Medium Cost	Expensive
Maintenance	Easy	Easy	Easy
Installation	Quick	Slow	Very Slow

Typical 4 mm Alubond - Ext Panel

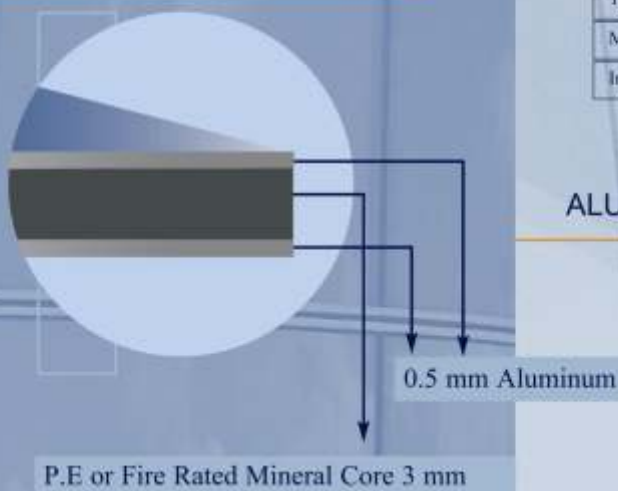

ALUBOND Panel Dimensions

Standard Width:	1220 mm
Available Widths:	1000 mm, 1250 mm, 1500 mm, 1550 mm
Standard Length:	2440 mm
Available Lengths:	Any length up to 4800 mm
Available Thickness:	1 mm, 2 mm, 3 mm, 4 mm, 5 mm, 6 mm

ALUBOND Product Range



Product Range	Alubond ACP Available Thickness						Coating / Finish
	1 mm	2 mm	3 mm	4 mm	5 mm	6 mm	
Alubond - Exterior	No	No	Yes	Yes	Yes	Yes	Kynar 300 PVDF
Alubond - Interior	Yes	Yes	Yes	Yes	Yes	Yes	Polyester
Alubond - Granite - Exterior	No	No	Yes	Yes	Yes	Yes	U.V. Stable Pet Film
Alubond - Granite - Interior	No	Yes	Yes	Yes	Yes	Yes	Pet Film
Alubond - Veneers - Exterior	No	No	Yes	Yes	Yes	Yes	U.V. Stable Pet Film
Alubond - Veneers - Interior	No	Yes	Yes	Yes	Yes	Yes	Pet Film
Alubond - Chameleon - Exterior	No	No	Yes	Yes	Yes	Yes	PVDF
Alubond - Chameleon - Interior	No	No	Yes	Yes	Yes	Yes	Polyester

Wind Load v/s Panel Dimension

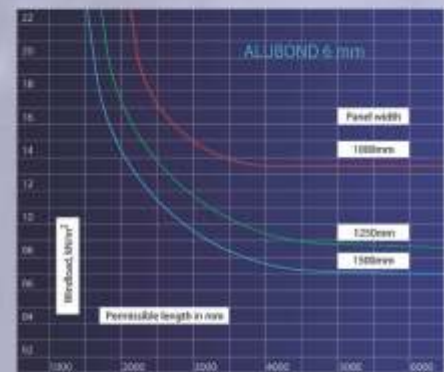
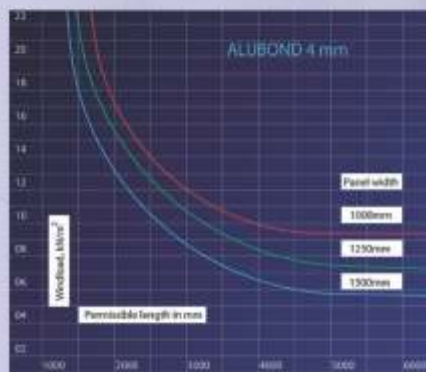

The above graphs show 4mm and 6mm thick ALUBOND panel's maximum permissible lengths based on the appointed wind load and panel width. The values given above are fixed only for panels that are supported on four sides.

ALUBOND U.S.A Test Report Data



130 Derry Court
York, PA 17402-9405
Tel : 717-764-7700
Fax : 717-764-4129
Website : www.archtest.com

Architectural Testing

Properties	Results	Test	Testing Laboratory
Thermal Conductance	5.79 Btu/hr.ft ² .°F (32.9 W/m ² .°K)	ASTM C 518	Architectural Testing, U.S.A
Tensile Strength Yield Strength Elongation	5,408 psi (37.3 MPa) 3,737 psi (25.8 Mpa) 6.1%	ASTM D 638	Architectural Testing, U.S.A
Deflection Temperature Under Load	211° C (411.8°F)	ASTM D 648	Architectural Testing, U.S.A
Coefficient of Linear Thermal Expansion	2.02 x 10 ⁻⁵ mm/mm °C (1.12 x 10 ⁻⁵ in. /in °F)	ASTM D 696	Architectural Testing, U.S.A
Impact Resistance	4092 psi (28.2 MPa)	ASTM D 732	Architectural Testing, U.S.A
Toxicity	Within Acceptable Limits	TCLP	Architectural Testing, U.S.A
Color Change at - 20°C	No Visible Change	ATI, York U.S.A	Architectural Testing, U.S.A
Color Change at 80°C	No Visible Change	ATI, York U.S.A	Architectural Testing, U.S.A
Delaminating at - 20°C	No Delamination	ATI, York U.S.A	Architectural Testing, U.S.A
Delaminating at 80°C	No Delamination	ATI, York U.S.A	Architectural Testing, U.S.A



Warrington Fire Research Centre Ltd,
Holmesfield Road, Warrington, UK WA1 2DS
Tel : int + (0) 1925 655116
Fax : int + (0) 1925 646672
Website : www.wfrc.co.uk

Method for Classification of the surface spread of Flame of Products	Classified As Class 1	BS 476 Part 7 1997	Warrington Fire Research, U.K.
Method of Test for Fire Propagation for Products	Fire propagation index, 1 = 2.6	BS 476 Part 6 1989	Warrington Fire Research, U.K.

Item	Unit	Thickness			Standard
		3 mm	4 mm	6 mm	
Density	g/cm ³	1.52	1.37	1.22	ASTM D792
Weight	kg/m ²	4.55	5.48	7.34	



ALUBOND Applications

ALUBOND's array of colors and finishes combined with the inherent capability of forming into different shapes and contours with durability and weather resistance makes ALUBOND an Architect's Dream! Major Corporations and Multi National Companies have a definitive desire to make their structures an expression of Personal Designer Statement. ALUBOND becomes a natural choice to achieve this objective. The possible applications are limited to The Architect's imagination. Some of the commonly used ALUBOND applications are:

■ Circular Columns

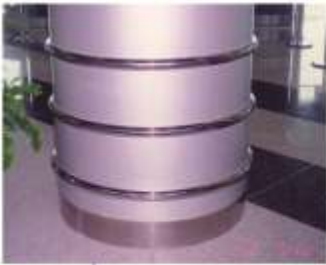

■ Building Fascades



■ Wall Paneling Concepts



■ Soffits and Beams



■ Metal Ceilings and Partitions



■ Exhibition and Display Stands



■ Shopfronts and Signages



■ Window Surrounds



■ Door Panels and frames



ALUBOND® U.S.A Granite Finish Panels



An innovative combination of high performance polymers multilayer technology in PVDF / Pet films has given ALUBOND the option of offering exotic textures and colors. Exterior grade panels in Marble, Granite, Veneer, double shaded Chameleon are available with 10 years weather resistance warranties.



Sawing



Jigging



Grooving



Punching



Shearing



Drilling



Bending



Rivetting



Spray Painting



Glueing

Alubond Process Methods
Alubond Process Methods
Alubond Process Methods

ALUBOND Folding and Routing Techniques

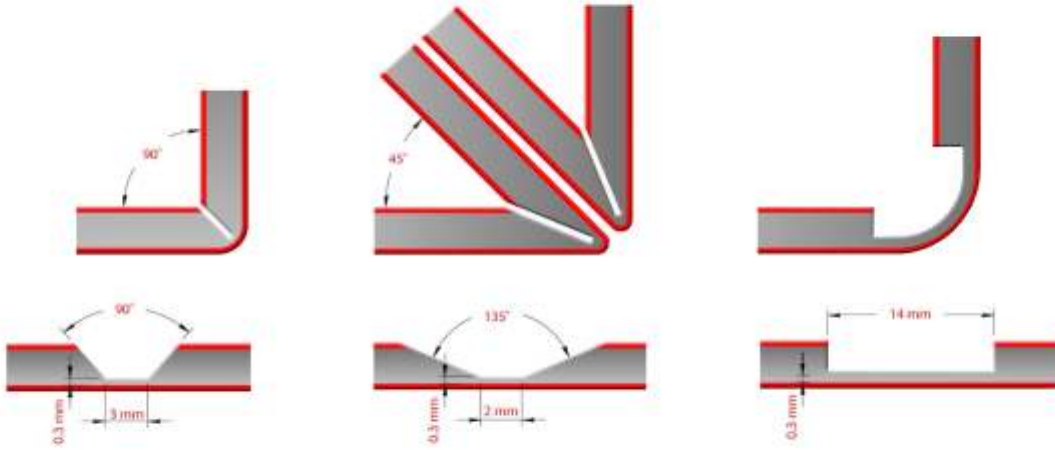

V-Shaped Groove for 90° folding

V-Shaped Groove for 45° folding

Bull nosed groove for foldings up to 150°



Bolted Fixing



Method of Panel Lamination

ALUBOND_{U.S.A} Test Certifications

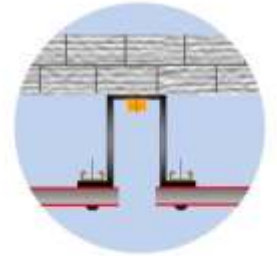

Exposed Riveted Fixing

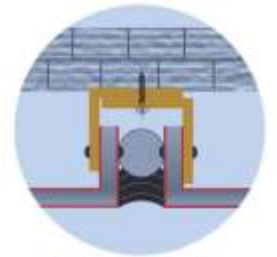

Mechanical Fixing



Free Suspended Fixing



Silicone Butt Joint

Alubond Fixing Methods



BS Standards



Architectural Testing
ASTM Standards



U.S.A. Incorporation

Alubond U.S.A - Middle East Plant

Eurocon Building Industries (F.Z.E)
P.B. No. 4819
Ajman, U.A.E
Tel : +971-6-7441450
Fax : +971-6-7425196
E-mail: mulk@alubond.com

U.S.A Sales Office

Alubond U.S.A Building Supply Inc
822, W. Lincoln Hyw No.301
Dekalb, IL 60115, U.S.A
Tel : + 815 558 8662
Fax : + 815 754 7744
E-mail : sales@alubond.com

Europe Sales Office

Alubond Europe
Appeldoorn - Holland
Tel : 31 55 33 23 09 50
E-mail : ernst@alubond.com

India Sales Office

Alubond India International
Mumbai, India
Tel: +91-22-2850 9762 / 64
E-mail: alubondindia@alubond.com



AMERICAN BUILDING TECHNOLOGIES INC



600 17th Street Suite 2800 South
Denver, CO 80202, U.S.A
Tel: (720) 904-9180
Fax: (720) 596-5070
E-mail: info@alubond.com
Website: www.alubond.com

